

# PRORIL

60Hz

GOFLOW Series, these non-clog pumps can handle solids up to 37 mm in diameter without clogging. These pumps are equipped with a semi-open channel impeller, a wide channel for the pump to pass solids from inflow to discharge with minimal blockage.

Sewage Pump

## GOFLOW 208/215/315

Non-clog Pump



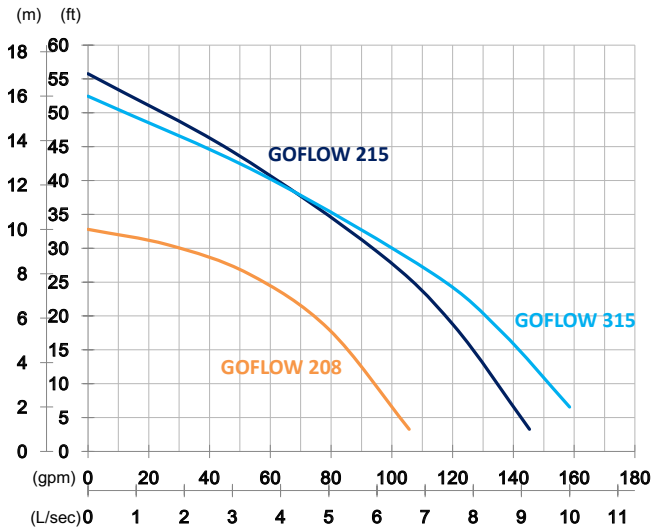

	GOFLOW 208	GOFLOW 215	GOFLOW 315
<b>OUTPUT</b>	1 HP (0.75 kW)	2 HP (1.5kW)	2 HP (1.5kW)
<b>OUTLET</b>	2" (50 mm)	2" (50 mm)	3" (80 mm)
<b>SOLID PASSAGE</b>	1" (26 mm)	1" (25 mm)	1" (25 mm)
<b>Weight</b>	49 lbs/22 kg	60 lbs/27 kg	60 lbs/27 kg
<b>HEAD</b>	Rated: 26 ft, 8 m Max: 33 ft, 10 m	Rated: 30 ft, 9 m Max: 56 ft, 17 m	Rated: 26 ft, 8 m Max: 52 ft, 16 m
<b>FLOW</b>	Rated: 53 gpm, 3.3 L/s Max: 106 gpm, 6.7 L/s	Rated: 95 gpm, 6 L/s Max: 145 gpm, 9.2 L/s	Rated: 114 gpm, 7.2 L/s Max: 159 gpm, 10 L/s

<b>Pump Type</b>	Electric Submersible Pumps	
<b>Motor</b>	<b>Phase</b>	1-Phase, 3-Phase
	<b>Type</b>	Induction Motor
	<b>Poles</b>	2 Pole (3450 rpm)
	<b>Insulation</b>	Class F
	<b>Protector</b>	Circle Thermal Protector
	<b>Starter</b>	1-Phase · Capacitor-Run, 3-Phase · D.O.L.
<b>Lubricant</b>	Food Grade (ISO VG32)	
<b>Specs.</b>	<b>Impeller Type</b>	Semi-Open Channel Cutter
	<b>Shaft Seal</b>	Double Mechanical Seal
		Silicon Carbide VS Ceramic/Carbon
	<b>Bearings</b>	C3 Shielded ball bearings
<b>Cable</b>	CSA-Certified PVC Jacketed Cables	
	33 ft (10 m) or longer upon request	
<b>Materials</b>	<b>Pump Casing</b>	Gray Iron
	<b>Impeller</b>	Gray Iron
	<b>Motor Frame</b>	Gray Iron
	<b>Motor Shaft</b>	Stainless Steel
<b>Max. Liquid Temperature</b>	40°C (104°F)	
<b>Max. Submersion Depth</b>	20 m (66 ft)	
<b>pH Range</b>	pH 5 - pH 8	
<b>Guide Rail</b>	GRL-02F (208 215)/GRL-03F (315)	

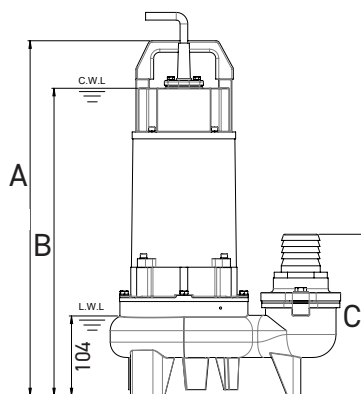
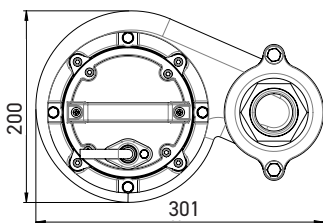

unit : mm

C.W.L : Continuous running water level  
L.W.L : Lowest running water level

	A	B	C
GOFLOW 208	434	372	211
GOFLOW 215	463	401	211
GOFLOW 315	463	401	246